



# ROLLO

## Chair

The Rollo chair has soft linear edges drowned in extra padding throughout making this “cigar lounge” style chair masculine in it’s design lines. A tight back and tight seat gives the appearance of modern hard lines, yet it’s as soft as a pillow. The “flange” stitch gives increased durability and shabby chic hint to an already formal looking piece.

All our leather and fabric furniture can be customized to colour of your choice. Made by Rawhide Leather Furniture in Toronto, Canada.

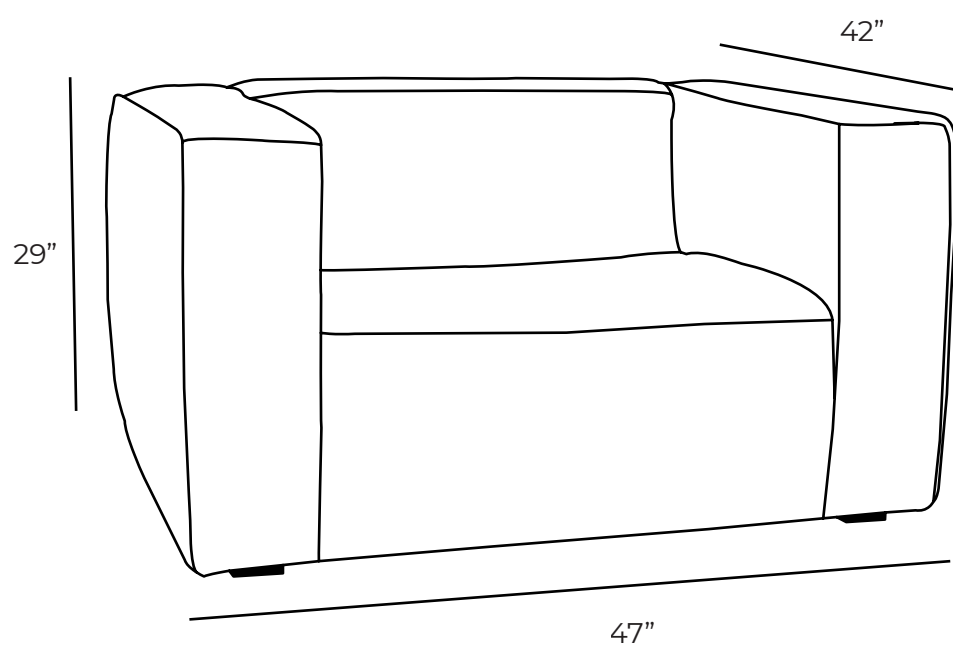

### Overall Dimensions

Arm Height	29"
Arm Width	12"
Seat Height	16"
Seat Depth	27"

### Measurements

	Length	Depth	Height
Chair as Shown	47"	42"	29"
Chair (Oversize)	59"	42"	29"

**\*All measurements are approximate**

### Available Styles

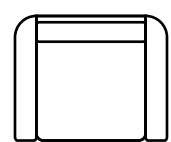

Chair

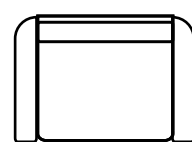

Chair (Oversize)

### Details

- Available in premium Italian top & full grain leathers or premium quality fabrics
- Handcrafted in Toronto, Canada by Rawhide
- Available in any depth and length
- Kiln-dried Canadian ethically sourced hardwood
- Eco-friendly construction
- Double-doweled frame
- Corner block joinery
- Platinum drop in coil suspension, 9 coils per seat, hand stuffed for noise dampening or evenly suspended steel coils
- Chairs available as a standard chair or an over-sized chair. There is an availability to customize to specific chair lengths.
- Choose standard fills: Super soft, tahoe, medium, firm (poly fiber wrapped around a soya-based high density foam core)
- Premium fill: Feather Deluxe (down, feather envelope encased in commercial grade foam core)
- Ultra cell foam (high density foam designed for commercial and contract use)
- All furniture available with your choice of over 20 decorative nail options in varying sizes and colours. There is also the ability to omit studs from any piece
- Wood block feet available in multiple sizes and finishes. Chrome and brushed steel legs also available in multiple sizes
- Rawhide Leather and Fabric Furniture offers you a lifetime warranty on the construction and springs on your piece. To find out more about the best warranty in Canada, please visit our “Construction” page.